

ADS N-12[®] HP 12”- 60” PIPE SPECIFICATION

Scope

This specification describes 12- through 60-inch (300 to 1500 mm) ADS N-12 HP pipe for use in gravity-flow storm drainage applications.

Pipe Requirements

- 12- through 30-inch (300 to 750 mm) pipe shall have a smooth interior and annular exterior corrugations and meet ASTM F2736
- 36- through 60-inch (900 to 1500 mm) pipe shall have a smooth interior and annular exterior corrugations
- Manning’s “n” value for use in design shall be 0.012.

Joint Performance

Pipe shall be joined with a gasketed integral bell & spigot joint meeting the requirements of ASTM F2736, for applicable diameters.

12- through 60-inch (300 to 1500 mm) shall be watertight according to the requirements of ASTM D3212. Spigots shall have gaskets meeting the requirements of ASTM F477. Gasket shall be installed by the pipe manufacturer and covered with a removable, protective wrap to ensure the gasket is free from debris. A joint lubricant available from the manufacturer shall be used on the gasket and bell during assembly.

12- through 60-inch (300 to 750 mm) diameters shall have a reinforced bell with a polymer composite band installed by the manufacturer.

Fittings

Fittings shall conform to ASTM F2736, for applicable diameters. Bell & spigot connections shall utilize a spun-on, welded or integral bell and spigot with gaskets meeting ASTM F477. Fitting joints shall meet the watertight joint performance requirements of ASTM F2736 or ASTM D3212.

Field Pipe and Joint Performance

To assure watertightness, field performance verification may be accomplished by testing in accordance with ASTM F2487. Appropriate safety precautions must be used when field-testing any pipe material. Contact the manufacturer for recommended leakage rates.

Material Properties

Polypropylene compound for pipe and fitting production shall be impact modified copolymer meeting the material requirements of ASTM F2736, Section 4.

Installation

Installation shall be in accordance with ASTM D2321 and ADS recommended installation guidelines, with the exception that minimum cover in traffic areas for 12- through 48-inch (300 to 1200 mm) diameters shall be one foot. (0.3 m) and for 60-inch (1500 mm) diameters, the minimum cover shall be 2 ft. (0.6 m) in single run applications. Backfill for minimum cover situations shall consist of Class 1, Class 2 (minimum 90% SPD) or Class 3 (minimum 95%) material. Maximum fill heights depend on embedment material and compaction level; please refer to Technical Note 2.04. Contact your local ADS representative or visit our website at www.ads-pipe.com for a copy of the latest installation guidelines.

Pipe Dimensions

	Nominal Diameter, in (mm)							
Pipe I.D. in (mm)	12 (300)	15 (375)	18 (450)	24 (600)	30 (750)	36 (900)	48 (1200)	60 (1500)
Pipe O.D.* in (mm)	14.5 (368)	17.6 (447)	21.2 (538)	28.0 (711)	35.4 (899)	41.1 (1044)	53.8 (1367)	66.5 (1689)
Minimum Pipe Stiffness @ 5% Deflection* #/in./in. (kN/m ²)	70 (480)	60 (411)	56 (385)	50 (343)	46 (320)	40 (275)	35 (240)	30 (205)

* Minimum pipe stiffness values listed; contact a representative for maximum values

N-12[®] HP 12" – 60" PIPE JOINT SYSTEM

(Joint configuration & availability subject to change without notice. Product detail may differ slightly from actual product appearance.)

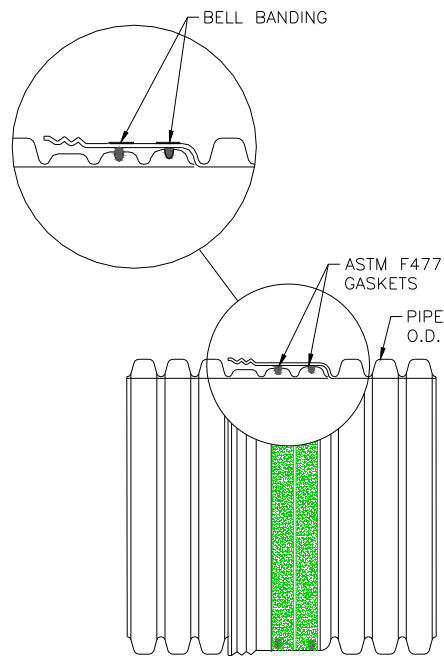

Check with a sales representative for regional availability

