

ADS N-12® WT IB PIPE SPECIFICATION

Scope

This specification describes 4- through 60-inch (100 to 1500 mm) ADS N-12 WT IB pipe for use in gravity-flow applications.

Pipe Requirements

N-12 WT IB pipe shall have a smooth interior and annular exterior corrugations.

- 4- through 10-inch (100 to 250 mm) shall meet AASHTO M252, Type S.
- 12- through 60-inch (300 to 1500 mm) shall meet AASHTO M294, Type S or ASTM F2306.
- Manning's "n" value for use in design shall be 0.012.

Joint Performance

Pipe shall be joined with the N-12 WT IB joint meeting the requirements of AASHTO M252, AASHTO M294, or ASTM F2306.

4- through 60-inch (100 to 1500 mm) shall be watertight according to the requirements of ASTM D3212. Gaskets shall be made of polyisoprene meeting the requirements of ASTM F477. Gaskets shall be installed by the pipe manufacturer and covered with a removable, protective wrap to ensure the gasket is free from debris. A joint lubricant available from the manufacturer shall be used on the gasket and bell during assembly.

12- through 60-inch (300 to 1500 mm) diameters shall have a reinforced bell with a bell tolerance device. The bell tolerance device shall be installed by the manufacturer.

Fittings

Fittings shall conform to AASHTO M252, AASHTO M294, or ASTM F2306.

Field Pipe and Joint Performance

To assure watertightness, field performance verification may be accomplished by testing in accordance with ASTM C969. Appropriate safety precautions must be used when field-testing any pipe material.

Material Properties

Virgin material for pipe and fitting production shall be high-density polyethylene conforming with the minimum requirements of cell classification 424420C for 4- through 10-inch (100 to 250 mm) diameters, and 435400C for 12- through 60-inch (300 to 1500mm) diameters, as defined and described in the latest version of ASTM D3350, except that carbon black content should not exceed 5%. The 12- through 60-inch (300 to 1500mm) virgin pipe material shall comply with the notched constant ligament-stress (NCLS) test as specified in Section 9.5 and 5.1 of AASHTO M294 and ASTM F2306 respectively.

Installation

Installation shall be in accordance with ASTM D2321 and ADS's published installation guidelines, with the exception that minimum cover in trafficked areas for 4- through 48-inch (100 to 1200 mm) diameters shall be one foot. (0.3 m) and for 60-inch (1500 mm) diameters, the minimum cover shall be 2 ft. (0.6 m) in single run applications. Contact your local ADS representative or visit our website at www.ads-pipe.com for a copy of the latest installation guidelines.

Pipe Dimensions

	Nominal Diameter												
Pipe I.D. in (mm)	4 (100)	6 (150)	8 (200)	10 (250)	12 (300)	15 (375)	18 (450)	24 (600)	30 (750)	36 (900)	42 (1050)	48 (1200)	60 (1500)
Pipe O.D.** in (mm)	4.8 (122)	6.9 (175)	9.1 (231)	11.4 (290)	14.5 (368)	18 (457)	21 (533)	28 (711)	36 (914)	42 (1067)	48 (1219)	54 (1372)	67 (1702)

*Check with sales representative for availability by region.

**Pipe O.D. values are provided for reference purposes only, values stated for 12- through 60-inch are ± 1 inch. Contact a sales representative for exact values.

N-12[®] WT IB JOINT SYSTEM

(Joint configuration & availability subject to change without notice. Product detail may differ slightly from actual product appearance.)

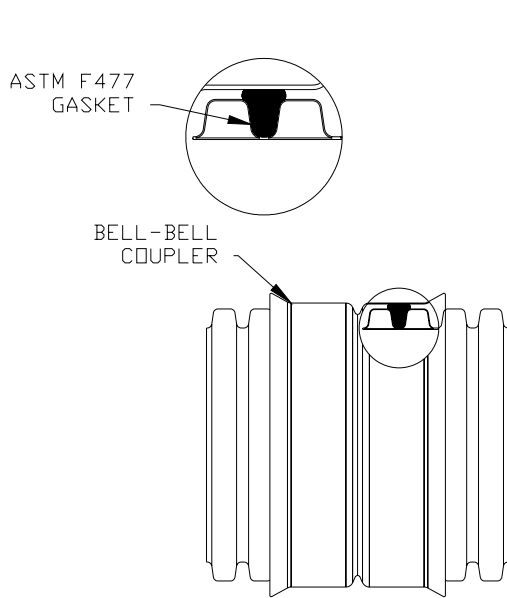

4" - 10"
(100-250 MM)

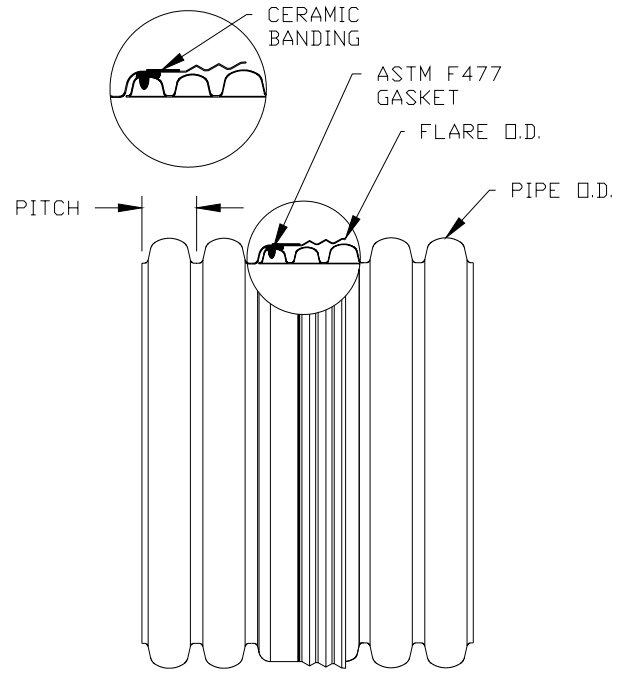

12" - 60"
(300-1500 MM)